

Solar radiation

Sun as Source of Energy

Solar energy is created by nuclear fusion that takes place in the sun. It is necessary for life on Earth, and can be harvested for human uses such as electricity. Fusion occurs when protons of hydrogen atoms violently collide in the sun's core and fuse to create a helium atom. This process, known as a PP (proton-proton) chain reaction, emits an enormous amount of energy.

The energy, heat, and light from the sun flow away in the form of electromagnetic radiation. About 30% of the solar energy that reaches Earth is reflected back into space. The rest is absorbed into Earth's atmosphere. The radiation warms the Earth's surface, and the surface radiates some of the energy back out in the form of infrared waves. As they rise through the atmosphere, they are intercepted by greenhouse gases, such as water vapor and carbon dioxide.

The Sun provides solar power directly and it is the primary source of energy. It also feeds plants through photosynthesis, which creates coal and oil (either directly as plant remains, or indirectly as animals remains — animals eat the plants). The Sun also causes evaporation of water, causing rain, which replenishes lakes, which drive hydroelectric power. The Sun even drives the weather on Earth, so it's responsible for wind energy.

Solar radiation

Solar radiation, often called the sunlight, is a general term for the electromagnetic radiation emitted by the sun. Solar radiation can be captured and turned into useful forms of energy, such as heat and electricity, using a variety of technologies.

Solar radiation is the energy emitted by the Sun, which is sent in all directions through space as electromagnetic waves. Emitted by the surface of the Sun, this energy influences atmospheric and climatological processes. It is also, directly and indirectly, responsible for

common phenomena, such as plant photosynthesis, keeping the planet at a temperature compatible with life and wind formation, which is essential for generating wind power.

Solar radiation at the Earth's surface

The atmosphere on the earth is depending on the amount of incoming energy from the Sun. If the earth energy explains that if the incoming and outgoing radiation is equal, then the atmosphere is in equilibrium. This must be done through phenomenon such as scattering, reflection, absorption and energy transformation. The majority of the energy that the Earth receives is from the Sun and only 0.03% comes from other sources.

Solar Radiation can be classified into two types:

1. Direct radiation and
2. Diffuse radiation

Direct radiation also known as “beam radiation” is used to describe solar radiation travelling on a straight line from the sun to the surface of the earth in the absence of the earth atmosphere.

Diffuse radiation, on the other hand, describes the sunlight that has been scattered by molecules and particles in the atmosphere but that has still made it down to the surface of the earth.

In simple terms, direct radiation has a definite direction but diffuse radiation follows a much more scattered, uncertain path. Because when the radiation is direct, the rays are all travelling in the same direction, an object can block them all at once. Therefore, it can be noted that shadows are only produced when direct radiation is blocked.

During day times when the sky is clear and the sun is very high in the sky, direct radiation is around 85% of the total insolation striking the ground and diffuses radiation accounts for about 15%. As the sun lowers into the sky, the percent of diffuse radiation keeps increasing until it reaches 40% when the sun is 10° above the horizon.

Atmospheric conditions like clouds and pollution also increase the chances of diffused radiation. On an extremely overcast day, pretty much 100% of the solar radiation is diffuse radiation. Technically speaking, the larger the percentage of diffuse radiation, the less the total insolation.

Pyranometer

A pyranometer is a type of actinometer used for measuring solar irradiance on a planar surface and it is designed to measure the solar radiation flux density from the hemisphere above within a wavelength range $0.3 \mu\text{m}$ to $3 \mu\text{m}$.

It was invented in the year 1893 by physicist & Swedish meteorologist namely Angstrom & Anders Knutsson.

The SI units of irradiance are W/m^2 (watts /square meter).

The WMO (World Meteorological Organization) was adopted this device which is changed with respect to the standards of ISO 9060. These devices are standardized depending on the WRR (World Radiometric Reference) and it is continued through WRC (World Radiation Center), Davon in Switzerland.

Construction

The pyrometer construction can be done using the following three components

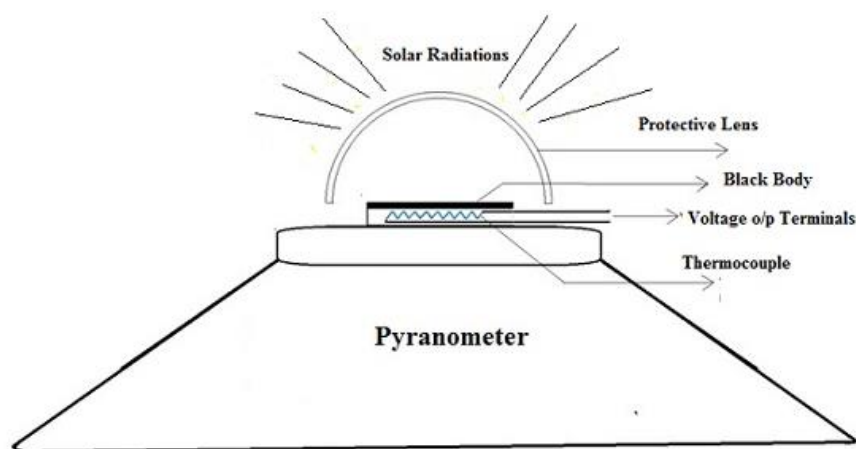

Thermopile

As the name implies, it uses a thermocouple used to notice dissimilarity in temperature between two surfaces. These are hot and cold accordingly. The labeled active surface is a black surface in flat shape and it is exposed to the atmosphere.

Glass Dome

Glass dome in the pyrometer limits the response of spectral from 300 nm to 2800 nm from 180 degrees of view. It also protects the thermopile sensor from rain, wind, etc. This construction of the second dome gives extra radiation protection among the inner dome.

Occultation Disc

The occultation disc is mainly used to measure the radiation of blocking beam & diffuse radiation from the panel surface.

Pyranometer Working Principle

The working principle of the pyranometer mainly depends on the difference in temperature measurement between two surfaces like dark and clear. The solar radiation can be absorbed by the black surface on the thermopile whereas the clear surface reproduces it, so less heat can be absorbed.

The thermopile plays a key role in measuring the difference in temperature. The potential difference formed within the thermopile is due to the gradient of temperature between the two surfaces. These are used to measure the sum of solar radiation.

But, the voltage which is generated from the thermopile is calculated with the help of a potentiometer. The information of radiation needs to be included through an electronic integrator.

Types of Pyranometer

Pyrometers are classified into two types like thermopile pyranometer, photodiode-based pyranometer.

Thermopile Pyranometer

This type of pyranometer is used to measure the flux density of the solar radiation from a 180° angle. Usually, it measures 300nm to 2800 nm with a largely level spectral sensitivity. The first generation of this pyranometer includes the sensor that works as an active part by dividing black & white sectors equally. Irradiation was measured from the two sectors like white & black within the temperature. Here, the black sector is exposed to the sun whereas the white sector doesn't expose to the sun.

These pyranometers are normally used in climatology, meteorology, building engineering physics, photovoltaic systems & climate change research.

Photodiode-based Pyranometer

Photodiode based pyrometer is also known as a silicon pyrometer. This is used to detect the segment of the solar spectrum between 400 nm & 900 nm. This photodiode changes the frequencies of the solar spectrum to current at high speed. This change will be influenced through the temperature with the raise in current, generated by the temperature rise.

These types of pyranometers are executed wherever the amount of irradiation of the noticeable solar spectrum needs to be measured and it can be done by using diodes with exact spectral responses.

These are used in cinema, lighting technique & photography; sometimes these are connected closely to photovoltaic system modules.

Pyranometer Applications

1. The solar intensity data can be measured.
2. Climatological & Meteorological studies
3. PV systems design
4. Locations of the greenhouse can be established.
5. Expecting the requirements of insulation for building structures

Sunshine Recorder

A sunshine recorder is a meteorological instrument used for recording the amount of sunlight that a particular location receives throughout a day.



A sunshine recorder is a device that records the amount of sunshine at a given location or region at any time. The results provide information about the weather and climate as well as the temperature of a geographical area. This information is useful in meteorology, science, agriculture, tourism, and other fields. It has also been called a heliograph.

Inside the recorder's adjustable frame are two important pieces: a paper strip and a glass sphere.

The glass sphere can focus the sunlight strongly enough to heat the paper. If the sky is clear, the paper is slowly burned as the sun moves across the sky. If there are clouds, the focused light will not be strong enough to burn the paper. It can be difficult to interpret the output of a sunshine recorder - rain can interfere with the paper's burning, and cloud cover is not an all-or-nothing affair. Furthermore, the paper strip must be manually changed every day.

Solar pond

A solar pond is a solar energy collector, generally fairly large in size, that looks like a pond. This type of solar energy collector uses a large, salty lake as a kind of a flat plate collector that absorbs and stores energy from the Sun in the warm, lower layers of the pond.

A solar pond may be used for generating heat or electricity or for desalination of water or for low temperature applications in industry and agriculture.

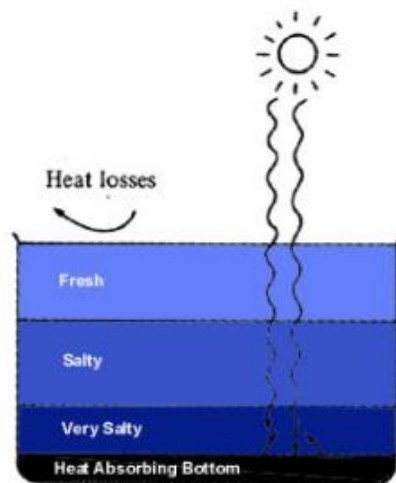

It works on a simple phenomenon. When water heats up a pond or lake, water rises up after getting warmed. In a solar pond, heat is trapped because salt is added, the concentration increasing with depth. Because of being heavy, it cannot rise and the heat generated by sunshine remains trapped. The temperature at the bottom of the pond will rise to over 90 °C while the temperature at the top of the pond is usually around 30 °C.

There are 3 distinct layers of water in the pond:

1. The top zone or the surface zone is called the UCZ (Upper Convective Zone) and is atmospheric temperature. It has little salt content.
2. The bottom zone is the hot zone also called the LCZ (Lower Convective Zone). Temperatures in the range of 70°– 85° C. It has a high concentration of salt. It energy in the form of heat.

3. The zone of separation is called NCZ (Non-Convective Zone). The salt content increases in this zone as the depth increases. Water in a particular layer cannot rise as the water above it is lighter due to lower salt content and vice versa. The salt gradient also acts as an insulator trapping the sunlight.

The energy obtained is rather low grade and can generate temperatures in the range of 70-80 °C. However, larger systems can be built using no more than a membrane to cover the pond which results in much lower costs. Usually, coastal locations are good locations for such solar ponds although theoretically they can be constructed anywhere.

Advantages:

1. Highly useful for rural areas because of the low cost involved.
2. A separate collector system is not needed in a solar pond setup.
3. The heat stored is on a very large scale and hence it can be used day and night, no storage is necessary in the form of batteries.

Disadvantages:

1. Larger land area requirement is often a deterrent.
2. The surface water keeps evaporating and needs to be replaced periodically.
3. Large supply of salt water is needed.
4. Some degree of maintenance is necessary- removing and preventing algae growth; maintain transparency in the pond and the salt gradient.

Importance of Solar Energy

1. It's Good for the Environment

The difference between solar energy and conventional electricity is that solar energy does not rely on the use of fossil fuels, does not pollute air or water, and does not contribute to global warming, making it the preferable option for many. Solar energy works with the earth's natural resources, whereas conventional electricity depletes or harms them.

2. It's a Reliable, Cost-Effective Energy Source

The sun is a renewable energy source. Fossil fuels will eventually run out, but sunlight won't. For that reason, solar energy is highly reliable. And unlike fossil fuels which are expensive to mine and utilize, it doesn't cost anything to receive sunlight.

3. It Saves You Money in the Long Run

Making the investment in running your home or building off of solar energy will save you considerably more money over time.

4. It Creates Jobs and Spurs Economic Growth

As of 2019, there were approximately 250,000 solar energy workers nationwide.

5. It Promotes Energy Independence

Energy independence means not having to rely on the power grid. Using solar energy, especially when paired with a backup battery system, allows you to not be tied to unreliable power grids when you need energy most.

6. Non-contaminating

Solar energy does not emit toxic substances or contaminants into the air, which can be very damaging to the environment and to human beings.

7. Improved grid security

When more people use power generated through natural resources, the grid will be more secure.

8. Solar Energy for Cooking

Using solar energy to cook is simple. Instead of cooking in a conventional oven, cooking in a solar oven will surprise you with the electricity bill.

9. Solar Water Heater

There are two types of solar water heaters to replace traditional water heaters viz, active solar hot water systems and Passive hot water systems.

Solar energy as a renewable energy

Solar energy is a renewable source of energy that is sustainable and totally inexhaustible, unlike fossil fuels that are finite.

Renewables include hydropower, solar thermal, solar photovoltaic, geothermal power, wind power, biogas, solid and liquid biomass, tidal power, wave power, ocean thermal gradients, as well as organic and inorganic waste material. Virtually all these renewable sources, with the exception of tidal power and geothermal energy, are directly or indirectly the result of solar insolation, as biomass is largely dependent on sunlight.

Renewable energy is defined as energy that comes from a source that can naturally replenish itself on a human timescale. And as long as the sun shines, we can use it to heat, cool and light our homes and businesses without polluting our precious planet with carbon dioxide (CO₂) emissions.

The energy sources available and produced due to solar energy as follows

Hydropower

Hydropower is our most mature and largest source of renewable power, producing about 10 percent of the nation's electricity. This is happening due to hydrological cycle depending on sun energy.

Bioenergy

Bioenergy is the energy derived from biomass (organic matter), such as plants. If you've ever burned wood in a fireplace or campfire, you've used bioenergy. These plants are growing due to sun energy absorption in photosynthesis.

Wind Energy

For hundreds of years, people have used windmills to harness the wind's energy. Today's wind turbines, which operate differently from windmills, are a much more efficient technology. The production of Winds is because of difference in temperatures at different places.

Ocean Energy

The ocean can produce two types of energy: thermal energy from the sun's heat, and mechanical energy from the tides and waves.

Solar energy is available in different forms continuously without change in magnitude. So that solar energy is a renewable energy.

Solar Thermal Systems

Principles of the conversion of solar radiation into heat

To estimate the size, the efficiency and the cost of equipment necessary to transfer a specified amount of heat in a given time, a heat transfer analysis must be made. The dimensions of a solar collector, a heat exchanger or a refrigerator depend not so much on the amount of heat to be transmitted but rather on the rate at which heat is to be transferred under given external conditions. From an engineering view point, the determination of the rate of heat transfer at a specified temperature difference is the key problem in sizing a solar collector to provide a given temperature in a home or building.

Heat transfer occurs mainly by three mechanisms. The first is by conduction through solid materials in the presence of a temperature difference. The second mechanism is radiation in which energy moves in space by electromagnetic waves. In a moving fluid, the fluid molecules gain heat or lose it by conduction or radiation and carry it by their movement from one place to another. This process, the third mechanism is called convection. The heat transfer may be accompanied by other physical phenomena such as heat generation within the medium, vapour condensation, liquid evaporation etc.

1. Conduction

The phenomenon of heat conduction is a process of propagation of energy between the particles of a body which are in direct contact and have different temperatures. Heat transfer in all types of metals are example of conduction.

2. Convection

Convection is the transfer of heat by a moving fluid, usually air or water. Natural convection is caused by the heating and cooling of the air in a room as it contacts objects. As air is warmed, it expands resulting in it having a lower density than the cooler air around it. Since its density is lower than the cool air, it will rise. As the air cools, its density increases and it will sink, starting the process all over again. This movement of air is known as convection current.

3. Radiation

Radiation is a process by which heat flows from a body at a higher temperature to a body at a lower temperature when the bodies are separated in space or even a vacuum exists between them. The heat energy transmitted by radiation is called radiant heat.

Flat Plate Collectors

A flat-plate collector (FPC) is a device to collect solar energy and transform it into thermal energy by using water as a working fluid. It is a heart of solar thermal devices that has many applications in a medium temperature range of nearly 100 °C from domestic to preheating to industrial sectors.

The overall idea behind this technology is pretty simple. The Sun heats a dark flat surface, which collects as much energy as possible, and then the energy is transferred to water, air, or other fluid for further use.

These are the main components of a typical flat-plate solar collector:

1. Black surface - absorbent of the incident solar energy
2. Glazing cover - a transparent layer that transmits radiation to the absorber, but prevents radiative and convective heat loss from the surface
3. Tubes containing heating fluid to transfer the heat from the collector
4. Support structure to protect the components and hold them in place
5. Insulation covering sides and bottom of the collector to reduce heat losses

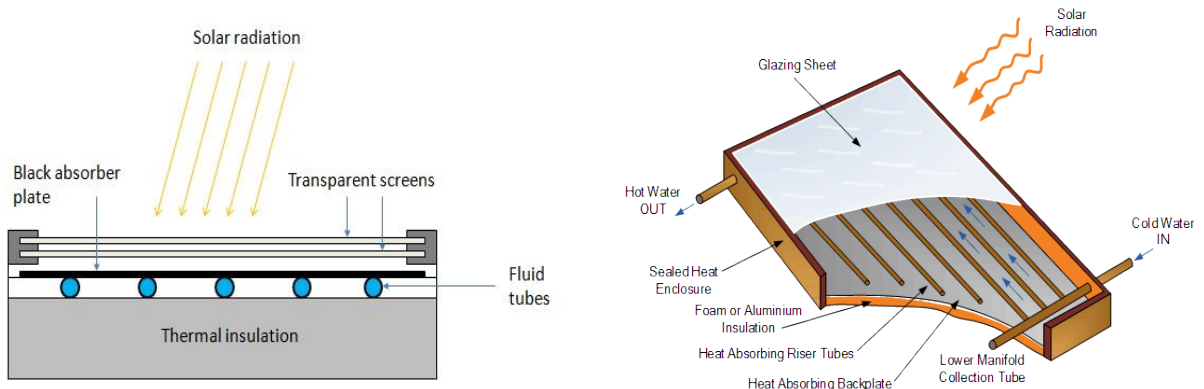

A solar flat plate collector typically consists of a large heat absorbing plate, usually a large sheet of copper or aluminium as they are both good conductors of heat, which is painted and chemically etched black to absorb as much solar radiation as possible for maximum efficiency.

This blackened heat absorbing surface has several parallel copper pipes or tubes called risers, running length ways across the plate which contains the heat transfer fluid, typically water.

Flat plate collectors can heat the fluid inside using either direct or indirect sunlight from a wide range of different angles. How hot the circulating water gets will depend mostly on the time of the year, how clear the skies are and how slowly the water flows through the collectors pipes.

The flat-plate systems normally operate and reach the maximum efficiency within the temperature range from 30 to 80 °C, however, some new types of collectors that employ vacuum insulation can achieve higher temperatures (up to 100 oC). Due to the introduction of selective coatings, the stagnant fluid temperature in flat-plate collectors has been shown to reach 200 °C.

The flat plate collectors can involve liquid or air heat transport.

Water is one of the common options as liquid fluid due to its accessibility and good thermal properties. One disadvantage of water is that it freezes during winter, which can damage the collector or piping system. Antifreeze mixtures can be used instead of pure water to alleviate the above-said problems. The common antifreeze components are ethylene glycol or propylene glycol.

The key considerations in flat plate collector design are maximizing absorption, minimizing reflection and radiation losses, and effective heat transfer from the collector plate to the fluids.

Concentrating solar collector

The amount of solar energy reaching the earth's surface is huge – almost 6000 times more than the power consumed by humans throughout the world.

There are two systems of converting sunlight into electricity.

1. Photovoltaic System (PV) and,
2. Concentrated Solar Power System (CSP).

A solar collector that uses reflective surfaces to concentrate sunlight onto a small area, where it is absorbed and converted to heat or, in the case of solar photovoltaic (PV) devices, into electricity. Concentrators can increase the power flux of sunlight hundreds of times.

Concentrating solar collectors in Concentrated Solar Power (CSP) facilities concentrate sunlight onto a receiver where it heats a heat transfer fluid that subsequently exchanges its absorbed heat to water to produce steam to power a steam turbine-generator (STG) to produce electricity.

Types of Concentrating Solar Collectors

Various types of concentrating solar collectors are as under:

1. Parabolic trough collector.
2. Power tower receiver.
3. Parabolic dish collector.
4. Fresnel lens collector.

Parabolic Trough Collector

It is a line focusing type collector. In this type of collector, the solar radiations falling on the area of the parabolic reflector are concentrated at the focus of the parabola.

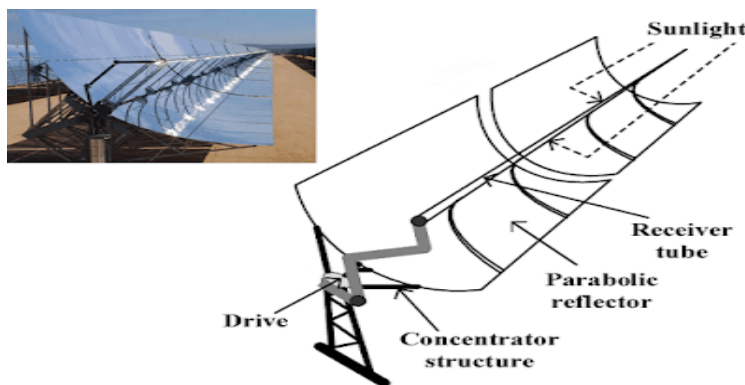

Power Tower Receiver

In this collector, the receiver is located at the top of the tower. It has a large number of independently-moving flat mirrors (heliostats) spread over a large area of ground to focus the reflected solar radiations on the receiver. The heliostats are installed all around the central tower.

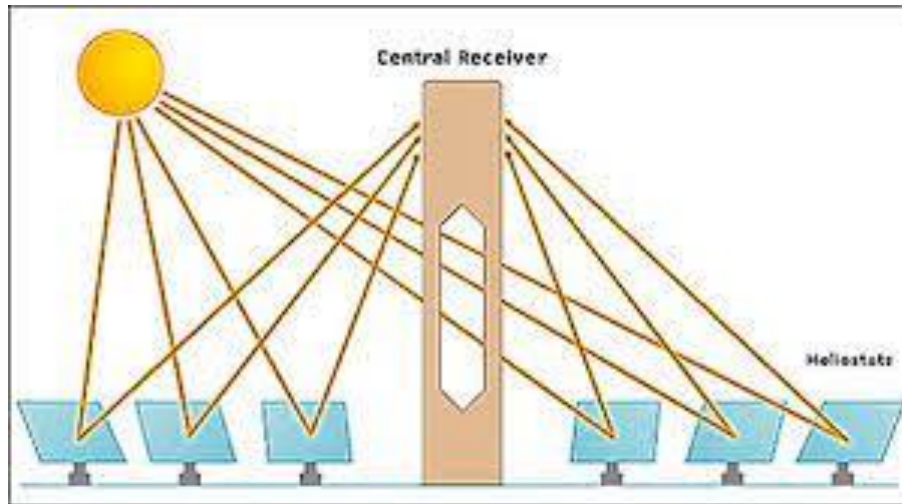

Parabolic Dish Collector

In these collectors, the receiver is placed at the focal point of the concentrator. The solar beam radiations are focused at a point where the receiver (absorber) is placed. The solar radiations are collected in the receiver.

A small volume of fluid is heated in the receiver to a high temperature. This heat is used to run a prime mover coupled with a generator.

Fresnel Lens Concentrating Collector

In this collector, a Fresnel lens which consists of fine, linear grooves on the surface of refracting material of optical quality on one side and flat on the other side is used.

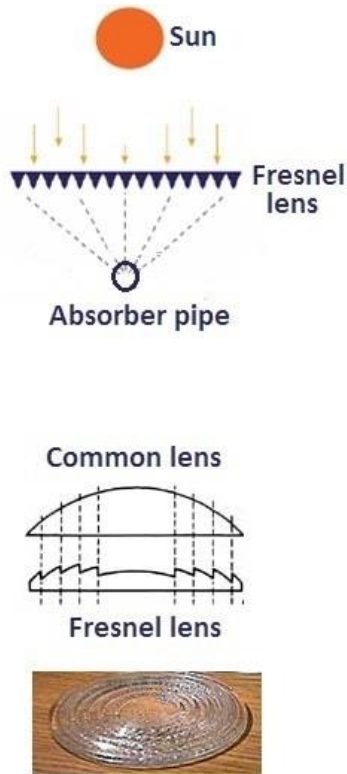

Solar thermal power plant

Solar thermal power plants are electricity generation plants that utilize energy from the Sun to heat a fluid to a high temperature. This fluid then transfers its heat to water, which then becomes superheated steam. This steam is then used to turn turbines in a power plant, and this mechanical energy is converted into electricity by a generator. This type of generation is essentially the same as electricity generation that uses fossil fuels, but instead heats steam using sunlight instead of combustion of fossil fuels. These systems use solar collectors to concentrate the Sun's rays on one point to achieve appropriately high temperatures.

There are two types of systems to collect solar radiation and store it:

1. passive systems and
2. Active systems.

Solar thermal power plants are considered active systems. These plants are designed to operate using only solar energy, but most plants can use fossil fuel combustion to supplement output when needed

Types of Plants

Despite the fact that there are several different types of solar thermal power plants, they are all the same in that they utilize mirrors to reflect and concentrate sunlight on a point. At this point the solar energy is collected and converted to heat energy, which creates steam and runs a generator. This creates electricity.

1. Parabolic Troughs

These troughs, also known as line focus collectors, are composed of a long, parabolic shaped reflector that concentrates incident sunlight on a pipe that runs down the trough. The collectors sometimes utilize a single-axis Solar tracking system to track the Sun across the sky as it moves from east to west to ensure that there is always maximum solar energy incident on the mirrors. The receiver pipe in the center can reach temperatures upward of 400°C as the trough focuses Sun at 30-100 times its normal intensity.



2. Parabolic Dishes

These are large parabolic dishes that use motors to track the Sun. This ensures that they always receive the highest possible amount of incoming solar radiation that they then concentrate at the focal point of the dish. These dishes can concentrate sunlight much better than parabolic troughs and the fluid run through them can reach temperatures upwards of 750°C .



3. Solar Towers

Solar power towers are large towers that act as a central receiver for solar energy. They stand in the middle of a large array of mirrors that all concentrate sunlight on a point in the tower. These large numbers of flat, sun tracking mirrors are known as heliostats. In the tower, there is a mounted heat exchanger where the heat exchange fluid is warmed. The heat concentrated to this point can be 1500 times as intense as incident sunlight.



Benefits and Drawbacks

Because these systems can generate steam of such high temperatures, the conversion of heat energy to electricity is more efficient. As well, these plants get around the issue of being unable to efficiently store electricity by being able to store heat instead. The storage of heat is more efficient and cost-effective than storing electricity.

Some of the drawbacks include the large amount of land necessary for these plants to operate efficiently. As well, the water demand of these plants can also be seen as an issue, as the production of enough steam requires large volumes of water.

Solar cooker

In our country energy consumed for cooking share in villages nearly 95%. Variety of fuels like firewood, coal, kerosene, cooking gas and agricultural waste are used. The energy crisis is effects in everyone. Thus solar cooker have a very relevant place in the present fuel consumption patterns. The first solar cooker was developed by Mr M K Ghosh in 1945 in India. He is a freedom fighter.

Basically there are three types of solar cookers depending on design

1. Flat plate box type solar cooker
2. Multi reflector type solar cooker
3. Parabolic concentrator type solar cooker

Flat plate box type solar cooker obtained 160°C of temperature with a single reflector. In multi reflector solar cooker triangular or rectangular reflectors are mounted on the oven body. They reflect the solar radiation into the cooking zone and obtained temperature is of the order of 200°C . With parabolic Disc concentrator type solar cooker temperature obtained of the order of 450°C . In which solar radiation are concentrated on to a Focal Point. The box type solar cooker is shown in figure 1. The Solar rays penetrate through the glass cover and absorbed by a black and metal tray kept inside the Solar Box. The solar radiation entering the box is a shorter wavelength. The higher wavelength radiation is not able to pass through the glass cover.

Two glass cover are provided to minimize heat lost due to convection. A rubber strip around the upper lid and the box provided to minimize the heat loss due to convection.

Insulating material like a glass, and saw dust or any other material is filled in the space between blackened tray and outer cover of the box to minimize the heat loss due to conduction. With this type of cooker is placed in the sun radiation the Blackened surface absorbing sun rays and the temperature inside the box starts rising.

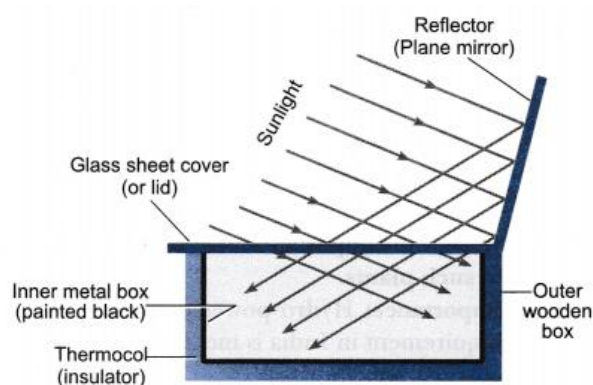

The cooking parts which are also blackened and are placed inside with food material get heat energy and food will be cooked in a certain period of time depending on the actual temperature obtained inside.

The temperature obtained depends upon the intensity of solar radiation and material of the insulation provided. The amount of solar radiation intensity can be increased by providing mirrors. The Solar Cooker is made up of inner and outer matter is wooden box with double glass sheet on it.

Solar cooker having dimensions $60 \times 60 \times 60 \text{ cm}^3$ cooks sufficient food material for a family of 5 to 7 people. Using these solar cooker vegetables took time for cook by half an hour to $1\frac{1}{2}$ hours. All types of dhals can be cooked between $1\frac{1}{2}$ TO 2 hours. Meat should be allowed to stay for 3 to 4 hours.

Merits of a solar cooker

1. No attention is needed during cooking as in other devices
2. No fuel is required
3. No pollution
4. Negligible maintenance cost
5. Vitamins of the food are not destroyed and nutritive and delicious with natural taste
6. No problem of overflowing

Limitations of solar cooker

1. One has to cook according to the sunshine the menu has to be pre-planned
2. Food cannot cook at shorter than and in the night or during cloudy days
3. It takes a comparatively more time with conventional methods
4. Chapatis are not cooked because high temperature for baking is required

Solar water heater

One of the applications of solar energy is direct thermal radiation. In which direct use of heat resulting from the absorption of solar radiation, provides hot water and to supply heat for agricultural requirements.

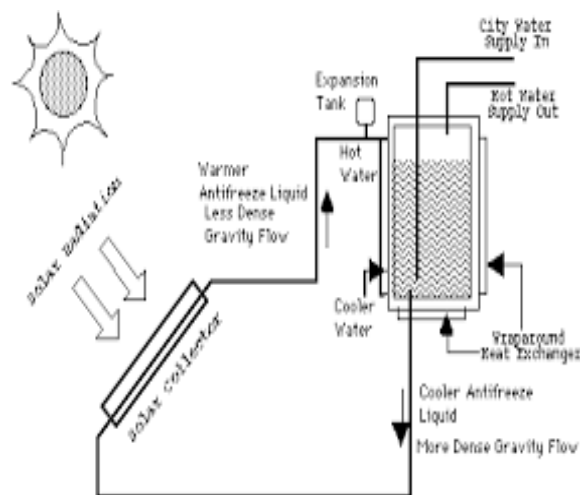

Solar water heating is one of the direct thermal applications of solar energy.

Solar water heater is as shown in the figure.

The basic elements of solar water heater is

1. Flat plate collector
2. Storage tank
3. Circulation system
4. Auxiliary heating system
5. Control of the system

Solar water heaters are commercially 3 types

1. Pressurized natural circulation solar water heater
2. Non pressurized natural circulation solar water heater
3. Forced circulation solar water heater

Natural circulation solar water heater is shown in figure. It consists of a flat plate collector facing south side with transparent cover glass. A separate highly insulated storage water tank and well insulated pipes connected the flat plate collector. The bottom of the storage tank is at least one feet above the flat plate collector. In which no auxiliary energy is required to circulate water through it. Circulation of water happens through natural convection.

As the water is heated in its passage through the conductor it is directly decreases and hence rises and flow into the top of the storage tank. Colder water from the bottom of the tank has a high density and enters the bottom of the collector for further heating. The density difference between hot water and cold water thus provide the driving force for the circulation of water through the collector and the storage tank.

As long as the sun signs the water circulate and getting warmer. The hot water can collect from the pipe connected to the storage tank at the same time cool water enter into the storage through another tube.

After sunset, rivers flow happens and lost its heat to the surroundings. To avoid reverse flow the storage tank kept at 1 feet above the collector. To provide heat during long cloudy periods an auxiliary heating system called electrical heater can be used as a backup for the solar system. Such heaters can be used extensively in rural areas and some urban areas where electricity is not available and expensive.

Solar dryer

Solar dryers are used to eliminate the moisture content from crops, vegetables, and fruits. The solar dryer consists of a box made up of easily available and cheap material like cement, galvanized iron, brick, and plywood. The top surface of the dryer is covered by transparent single and double-layered sheets. The inside surface is colored black to absorb the incoming solar

radiation. Since the box is insulated, the inside temperature of the box is raised. The air is ventilated through the small holes at the top of the box. As the inside air gets warm, it rises by the natural circulation process and removes the moisture from the fruits, vegetables, and the crops placed in trays inside the box. To fill the vacuum, fresh air comes in by a forced draught process and the process continues, as shown in Figure.

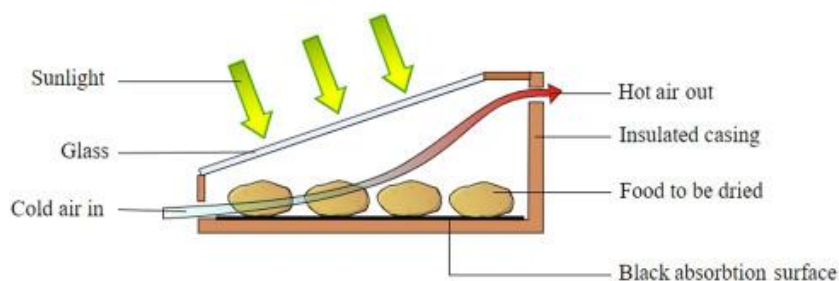

Direct solar dryers expose the substance to be dehydrated to direct sunlight. Historically, food and clothing was dried in the sun by using lines, or laying the items on rocks or on top of tents. In Mongolia cheese and meat are still traditionally dried using the top of the tent as a solar dryer. In these systems the solar drying is assisted by the movement of the air that removes the more saturated air away from the items being dried. More recently, complex drying racks and solar tents were constructed as solar dryers.

Uses of solar dryer

Solar dryers can be utilized for various domestic purposes. They also find numerous applications in industries such as textiles, wood, fruit and food processing, paper, pharmaceutical, and agro-industries. Solar driers have the following advantages.

1. Solar dryers are more economical compared to dryers that run on conventional fuel/electricity.
2. The drying process is completed in the most hygienic and eco-friendly way.
3. Solar drying systems have low operation and maintenance costs.
4. Solar dryers last longer. A typical dryer can last 15-20 years with minimum maintenance.

Limitations

1. Drying can be performed only during sunny days, unless the system is integrated with a conventional energy-based system.
2. Due to limitations in solar energy collection, the solar drying process is slow in comparison with dryers that use conventional fuels.
3. Normally, solar dryers can be utilized only for drying at 40-50°C.

One modern type of solar dryer has a black absorbing surface which collects the light and converts it to heat; the substance to be dried is placed directly on this surface. These dryers may have enclosures, glass covers and/or vents in order to increase efficiency.

Solar greenhouses

Solar greenhouses capture the light energy of the sun and convert it into heat energy and store it. This heat is used to keep warm-weather plants from suffering during the intense cold of winter nights. Many out of season plants too are grown in a greenhouse during the winter months.

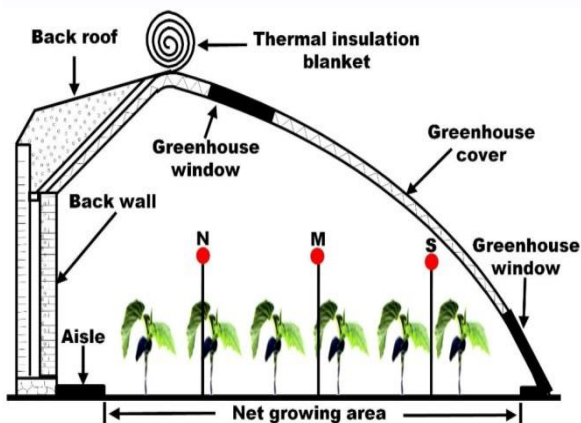

The glass or plastic in a greenhouse's walls and roof let in the short waves of the solar light. This is then absorbed by the earth and plants in a greenhouse and converted into heat energy. This energy cannot escape through the glass or plastic because the heat waves are longer than the light waves.

The heated floor then warms the air immediately above it. This makes the air lighter and it rises, being replaced by cooler air from the top. Through this convection method, the entire greenhouse is heated.

Working of Solar Greenhouse

In a solar greenhouse you apply the same principle, except that the greenhouse is aligned to the sun. The south and west of the greenhouse have large glass windows to the south and east. The north side has black painted stone blocks to help absorb and retain the heat. Any surface that does not have to retain heat is painted white to reflect the heat. In other words, solar greenhouses have oriented glazing to get the maximum benefit from the sun's energy. It is designed to minimize heat loss in winter and uses natural ventilation to reduce heat in summer.'

Besides this a greenhouse that is full of plants is warmer than one without plants. This is because plants give out carbon dioxide, which heats up the air inside the greenhouse. Composts too give out carbon dioxide and help keep the atmosphere of a greenhouse warm in the night time.

Both glass and clear plastic can be used to build greenhouses. Plastic is less expensive, but will not last as long as a glass greenhouse. So, you need to choose a material in conjunction with your long-term plans.

In winter you can use an inexpensive exhaust fan to blow in heat from the greenhouse into your home. This will be less expensive than heating up your living room by conventional methods.

Solar distillation

Solar distillation is a process in which the energy of the sun is directly used to evaporate freshwater from sea water. The process has been used for many years, usually for small-scale applications.

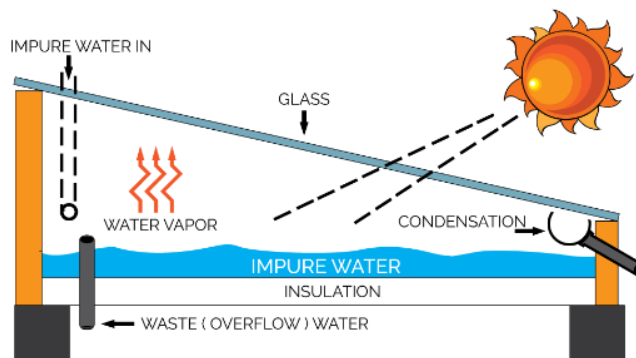

Implementation

Solar water distillers find application mostly in remote areas where there is limited access to freshwater and centralized distribution systems. In these areas technical expertise is made use of to introduce the system and personnel in usage and maintenance of the system. An important criterion for installation of these systems is that the area should be flat and open with good access to water and sunlight. The “roof” of the system is fitted with a transparent glass cover tilted at an angle so as to catch maximum sunlight. Solar energy can access the underlying still basin by penetrating through the cover. The untreated water is collected in the still basin. Solar energy heats up this water and then evaporates and separates it from the contaminants. The slanted cover funnels the condensed water into a pipe tube, which is attached to a storage container so it can be used for drinking water.

Solar distillation systems are classified into two groups in terms of energy supply:

- (1) Passive or conventional and
- (2) Active solar stills (Solar water distillers).

The passive solar stills use the solar energy as the only source of thermal energy. In active solar stills, extra thermal energy, from a solar collector or any available waste heat is

directed to the solar still for faster evaporation. Humidification-dehumidification (HD) process, described in the next paragraph, is an active solar technique.

Solar stills are the simplest device that are used to obtain freshwater using solar energy as the sole energy supply. The basic principle of solar water distillation is simple, as distillation replicates the way nature makes rain. In such systems energy is required only to power the circulating water pumps.

Solar water distillers are usually used in remote areas where there is limited access to freshwater. The basic principles of solar water distillation are simple, yet effective, as distillation replicates the way nature makes rain. A solar still works on two scientific principles: evaporation and condensation.

Most stills are simple black bottomed vessels filled with water and topped with clear glass or plastic. Sunlight that is absorbed by the black material speeds the rate of evaporation. The evaporation is then trapped by the clear topping and funneled away. Most pollutants do not evaporate, so they are left behind. Most stills need to be about six square meters in size to produce enough water for a single person for a day. Multiple solar distillation systems are required to produce a large quantity of distilled water.

Advantages:

5. It is a relatively cheap and low-maintenance system.
6. It can be used at the household level and scaled up through programmatic approaches.
7. There are climate change adaptation and mitigation benefits.
8. There are no energy costs.
9. There are no moving parts.

Disadvantages:

1. Rate of distillation is usually very slow (6 litres of water per sunny day).
2. It is not suitable for larger consumptive needs.
3. The materials required for the distiller may be difficult to obtain in some areas.

4. If not correctly disposed of, the distillation process waste stream can be a potential source of environmental pollution (high concentrations of salts and pollutants).
5. Solar energy is only available during the day.

UNIT-III

SOLAR PHOTO VOLTAIC SYSTEMS

Convert sun light into electricity

A photovoltaic (PV) cell, commonly called a solar cell, is a non-mechanical device that converts sunlight directly into electricity. Some PV cells can convert artificial light into electricity.

Sunlight is composed of photons, or particles of solar energy. These photons contain varying amounts of energy that correspond to the different wavelengths of the solar spectrum.

A PV cell is made of semiconductor material. When photons strike a PV cell, they may reflect off the cell, pass through the cell, or absorbed by the semiconductor material. Only the absorbed photons provide energy to generate electricity. When the semiconductor material absorbs enough sunlight (solar energy), electron is dislodged from the material's atoms. Special treatment of the material surface during manufacturing makes the front surface of the cell more receptive to the dislodged, or free, electrons so that the electrons naturally migrate to the surface of the cell.

The movement of electrons, each carrying a negative charge, toward the front surface of the cell creates an imbalance of electrical charge between the cell's front and back surfaces. This imbalance, in turn, creates a potential difference like the negative and positive terminals of a battery. Electrical conductors on the cell absorb the electrons. When the conductors are connected in an electrical circuit to an external load, such as a battery, electricity flows in the circuit.

Photovoltaic effect

The photovoltaic effect is a process that generates voltage or electric current in a photovoltaic cell when it is exposed to sunlight. It is this effect that makes solar panels useful, as it is how the cells within the panel convert sunlight to electrical energy. The photovoltaic effect was first discovered in 1839 by Edmond Becquerel. When doing experiments involving wet

cells, he noted that the voltage of the cell increased when its silver plates were exposed to the sunlight.

The photovoltaic effect occurs in solar cells. These solar cells are composed of two different types of semiconductors –

- a) p-type and
- b) n-type - that are joined together to create a p-n junction.

By joining these two types of semiconductors, an electric field is formed in the region of the junction as electrons move to the positive p-side and holes move to the negative n-side. This field causes negatively charged particles to move in one direction and positively charged particles in the other direction.

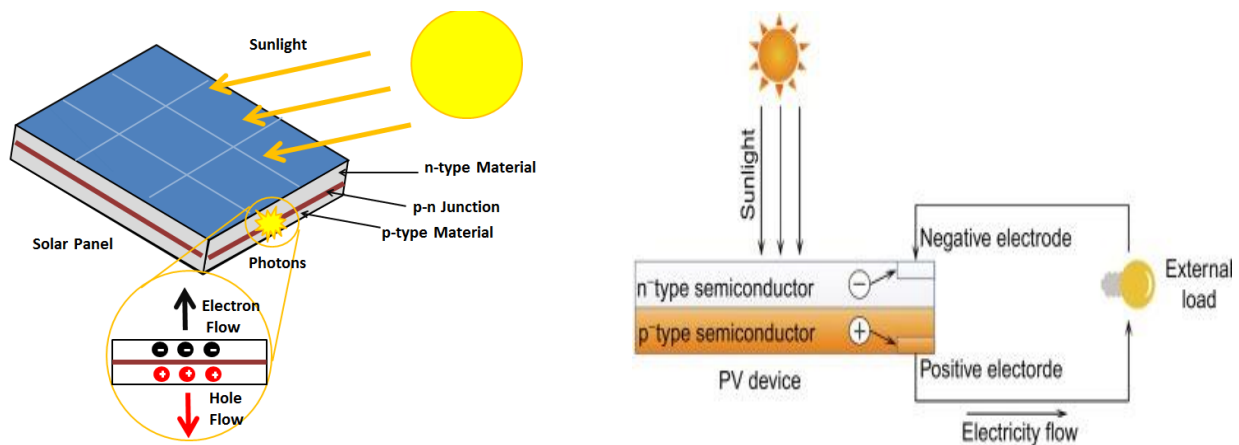

Light is composed of photons, which are simply small bundles of electromagnetic radiation or energy. These photons can be absorbed by a photovoltaic cell - the type of cell that composes solar panels. When light of a suitable wavelength is incident on these cells, energy from the photon is transferred to an atom of the semiconducting material in the p-n junction. Specifically, the energy is transferred to the electrons in the material. This causes the electrons to jump to a higher energy state known as the conduction band. This leaves behind a "hole" in the valence band that the electron jumped up from. This movement of the electron as a result of added energy creates two charge carriers, an electron-hole pair.

Working Principle of Solar Cell

When light reaches the p-n junction, the light photons can easily enter in the junction, through very thin p-type layer. The light energy, in the form of photons, supplies sufficient energy to the junction to create a number of electron-hole pairs. The incident light breaks the thermal equilibrium condition of the junction. The free electrons in the depletion region can quickly come to the n-type side of the junction. Similarly, the holes in the depletion can quickly come to the p-type side of the junction. Once, the newly created free electrons come to the n-type side, cannot further cross the junction because of barrier potential of the junction.

Similarly, the newly created holes once come to the p-type side cannot further cross the junction because of same barrier potential of the junction. As the concentration of electrons becomes higher in one side, i.e. n-type side of the junction and concentration of holes becomes more in another side, i.e. the p-type side of the junction, the p-n junction will behave like a small battery cell. A voltage is set up which is known as photo voltage. If we connect a small load across the junction, there will be a tiny current flowing through it.

DIFFERENT TYPES OF SOLAR CELL

Solar cells are available in different types. When we take a closer look at the different types of solar cells available, it makes things simpler, both in terms of understanding them and also choosing the one that suits you best.

We'll start by listing the available types below. If you want to learn about them in more detail, you can do so here.

1. Crystalline silicon cells
2. Monocrystalline cells
3. Polycrystalline cells
4. Thin film solar cells

Presently, around 90% of the world's photo voltaic cells are based on some variation of silicon, and around the same percentage of the domestic solar panel, systems use the crystalline silicon cells. Crystalline silicon cells also form the basis for mono and polycrystalline cells.

The silicon that is in solar cells can take many different forms. However, the thing that matters most is the purity of the silicon. This is because it directly affects its efficiency. What purity means, in this case, is the way in which the silicon molecules have been aligned. The better the alignment, the purer the resulting silicon is. This, ultimately, leads to better conversion rates of sunlight into electricity.

Monocrystalline cells

Mono crystalline solar cells are made from single crystalline silicon. They are very distinctive in their appearance as they are often coloured, and the cells hold a cylindrical shape. In order to keep the costs low and performance at optimal levels, manufacturers cut out the four sides of the mono crystalline cells. This gives them their recognizable appearance.

Advantages

Here are some of the advantages of mono crystalline solar cells:

1. They have the highest level of efficiency at 15-20%
2. They require less space compared to other types due to their high efficiency
3. Manufacturers state that this form of solar cell lasts the longest, with most giving them a 25-year warranty
4. They perform better in low levels of sunlight, making them ideal for cloudy areas

Disadvantages

Here are some of the disadvantages to mono crystalline solar cells:

1. They are the most expensive solar cells on the market, and so not in everyone's price range
2. The performance levels tend to suffer from an increase in temperature. However, it is a small loss when compared to other forms of solar cell
3. There is a lot of waste material when the silicon is cut during manufacture

Polycrystalline Solar Cells

The polycrystalline solar panels were first introduced to the public in 1981. Unlike the mono crystalline cells, polycrystalline ones do not require each of the four sides to be cut. Instead, the silicon is melted and poured into square moulds. These then form perfectly shaped square cells.

Advantages

Here are some of the advantages of polycrystalline solar cells:

1. The manufacturing process is cheaper and easier than the mono crystalline cells
2. It avoids silicon waste
3. High temperatures have less negative effects on efficiency compared with mono crystalline cells. This makes the polycrystalline cells more attractive to people in warmer areas as the price is lower

Disadvantages

Here are some of the disadvantages to polycrystalline solar cells:

1. Efficiency is only around 13-16% due to low levels of silicon purity. So they are not the most efficient on the market
2. They have lower output rates which make them less space efficient. So more roof space is needed for installation

Thin Film Solar Cells

Thin film solar cells are manufactured by placing several thin layers of photovoltaic on top of each other to create the module. There are actually a few different types of thin film solar cell, and the way in which they differ from each other comes down to the material used for the PV layers. The types are as follows:

- Amorphous silicon
- Cadmium telluride
- Copper indium gallium selenide
- Organic PV cells

Depending on the technology that has been used, the efficiency rates for thin film solar cells tend to vary from 7% to 13%. Since 2002, the knowledge levels and popularity for thin film solar cells has risen dramatically, which also means that research and development have been increased. Due to this, we can expect future models to hold efficiency rates of 10-16%.

Advantages

Here are some of the advantages of thin film solar cells:

1. They can be manufactured to be flexible, making them widely applicable to a range of situations and building types
2. Mass production is easy to achieve, making them potentially cheaper to produce than crystalline solar cells
3. Shading has a similar effect on their efficiency

Disadvantages

Here are some of the disadvantages of thin film solar cells:

1. They are not ideal for domestic use as they take up a lot of space
2. Low space efficiency means that they will cause further expenses in the form of enhancers, like cables or support structures
3. They have a shorter lifespan and so shorter warranty periods
4. Solar cells are different types depending on the materials used

1. Amorphous solar cell

Amorphous solar cells used in smallest solar panels such as in calculators or Garden lamps. Amorphous solar cells made by depositing a thin film of silicon onto a sheet of another material such as Steel.



2. Bio hybrid solar cells

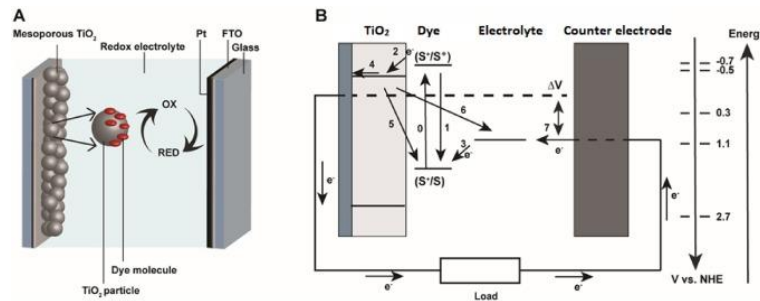

A bio hybrid solar cell is made using a combination of organic matter and inorganic matter.

3. Cadmium telluride photovoltaic cell (CDTE)

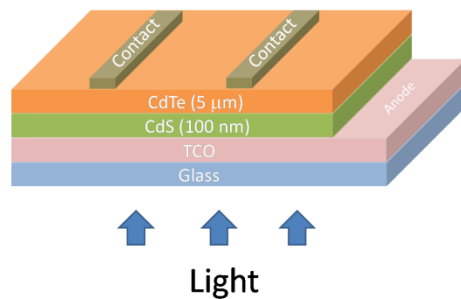

Cadmium telluride photo voltaic cell is based on the use of cadmium telluride thin semiconductor layer designed to absorb solar radiation

4. Copper Indium Gallium Selenide solar cell (CIGS)

Copper Indium Gallium Selenide solar cell manufactured by depositing a thin layer of copper, indium, gallium and selenide on glass or plastic backing along with electrodes.

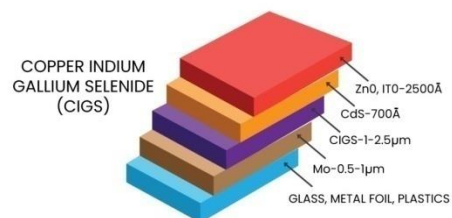

5. Crystalline Silicon Cell

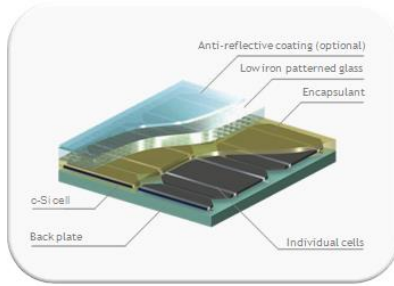

Crystalline Silicon solar cell is the crystalline form of silicon either multi Silicon or a mono crystalline Silicon as a continuous crystal. These cells are assembled into solar panels as part of a photo Voltaic system to generate solar power from sunlight.

7. A Dye Sensitized Solar Cell

A Dye Sensitized Solar Cell sensitized solar cell is a low cost of solar cell belonging to the group of thin film solar cells. It is based on a semiconductor formed between a photo sensitized and electrode.

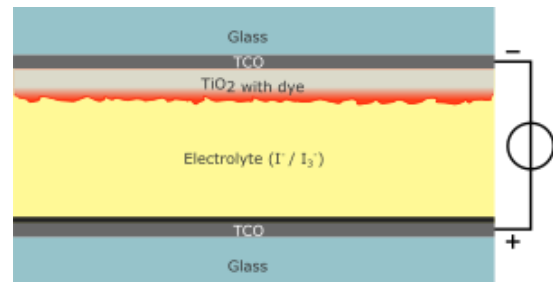

7. Hybrid Solar Cells

Hybrid solar cell combines advantages of both organic and inorganic semiconductors. These are not only low cost but also scalable solar power convection.

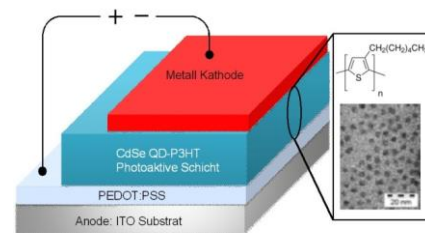

8. A Luminescent Solar Concentrator

This solar cell is a device for concentrating solar radiation in particular to produce electricity.

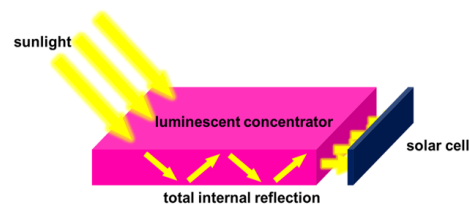

9. Mono crystalline Silicon Solar Cell

In which single crystal silicon is the base material for Silicon chips used in all electronic equipment today.



10. Multi Junction Solar Cells

These cells with multiple PN junction made of different semiconductor materials.

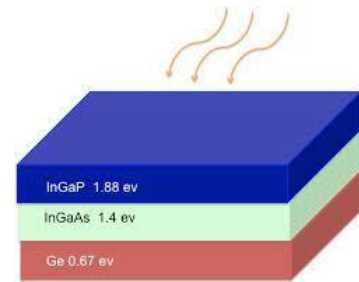

11. Nano Crystal Solar Cells

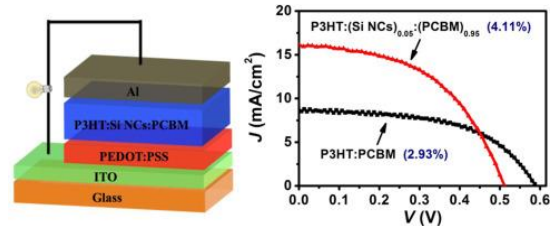
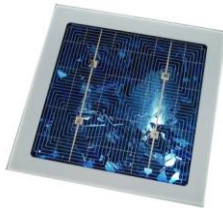

These solar cells based on a substrate with a coating of Nano crystals. The Nano crystals are based on silicon, cadmium telluride and the substrates are generally Silicon organic conductor.

12. Photo Electrochemical Cells

The solar cell produces electrical energy or hydrogen in a process similar to the electrolysis of water.

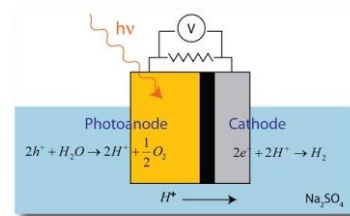

13. An Organic Solar Cell

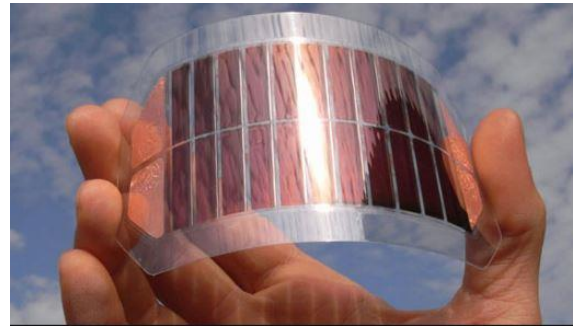
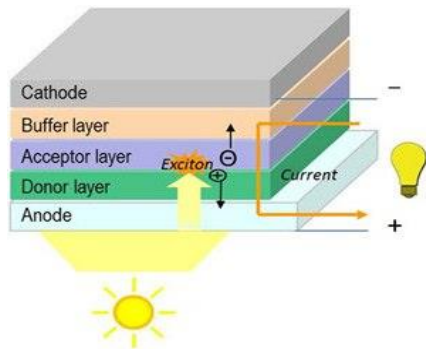

This is a type of photovoltaic cell that uses organo electronics, a branch of electronics that deals with conductive organic Polymers or small organic molecules.

14. Quantum Dot Solar Cell

This is solar cell designs that uses Quantum dot as the absorbing photovoltaic material.

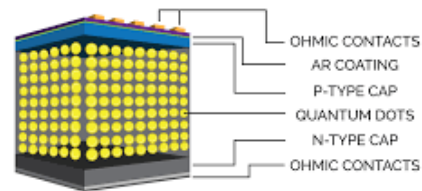

Series and Parallel Connections of Solar panels

When building a solar power system, the panel's array connection is the vital part that determines how many voltage and amps comes out from the panels. The three main methods you can connect multiple panels are connecting them in series, parallel, and series-parallel.

Series Wiring:

Series wiring is when the voltage of a solar array is increased by wiring the positive of one solar module to the negative of another solar module. This is similar to installing batteries in a flashlight. As you slide the batteries into the flashlight tube the voltage increases.

To wire solar panels in series, connect the positive terminal on the first panel to the negative terminal on the next, and so on. The resulting voltage will be the sum of all of the panel

voltages in the series. However, the total current will be equal to the output current of a single panel.

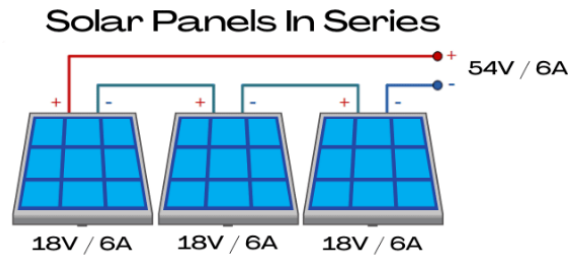

For example, in the graphic above, we have three 18-volt, 6-amp panels wired in series. The output voltage is 54 volts ($18V + 18V + 18V = 54V$), yet the output current is still 6 amps.

Parallel Wiring:

Parallel wiring increases the current (amps) output of a solar array while keeping the voltage the same. Parallel wiring is when the positives of multiple modules are connected together and all the negatives for the same modules are connected together.

To wire solar panels in parallel, connect all of the positive terminals on each panel together and then do the same for the negative terminals. The resulting current will be the sum of all of the panel amperages in the parallel array. However, the total voltage will be equal to the output voltage of a single panel.

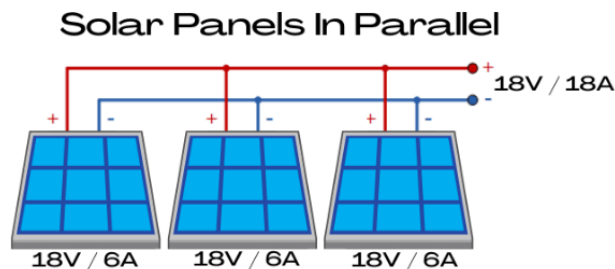

For example, in the graphic above, we have three 18-volt, 6-amp panels wired in parallel. The output current is 18 amps ($6A + 6A + 6A = 18A$), yet the output voltage is still 18 volts.

Battery chargers

Rechargeable batteries have been around for more than 150 years, and the concept of the first lead-acid rechargeable battery is still being used today. The charging method for batteries has made some strides in becoming more eco-friendly and solar energy is one of the more sustainable options for recharging batteries.

Solar panels can be used to charge batteries, but, more often than not, a battery cannot directly plug into the solar panel itself. A charge controller will usually be needed, which protects the battery by converting the panel's voltage output to one that is suitable for the battery being charged.

Charging your batteries with a solar panel is a great way to use clean, renewable energy. However, before you can get started, you'll need to install a charge controller, which regulates the voltage from the solar panel as it's transferred to the battery. Otherwise, on sunny days, the solar panel may produce more energy than your battery can handle, which can damage the battery.

Solar Battery Charging

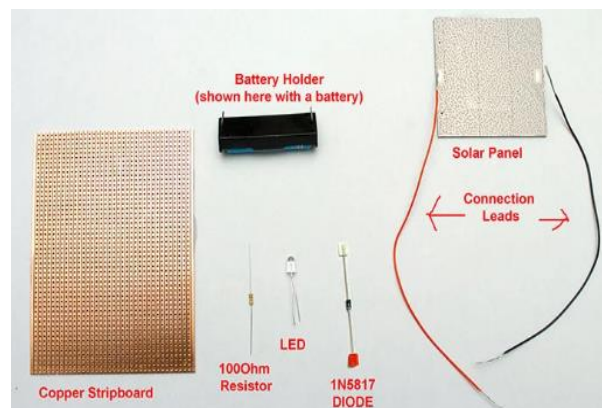
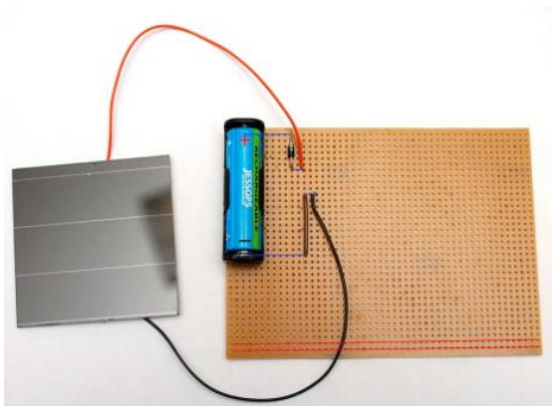

The following items are required to make simple solar battery charger.

The Copper Strip board: The Copper Strip board contains rows of copper tracks. Each track is electrically separate from its neighbour. It contains holes for your components.

The Batter Holder: batteries comes with two pins, one for the positive and one for the negative ends, they will be soldered into the strip board.

100 Ohm resistor: 100 Ohm resistor - at one point this was needful in the kit as the LED couldn't cope with some of the voltages in the experiments.

LED: This is a high intensity light emitting diode at 3.2-3.6V forward voltage range and at 20mA current.

1N5817 DIODE: This diode allows current to flow in only one direction - this prevents battery power discharging through the solar panel at night. It drops about 0.2V from the system. This blocking diode also needs placing in the circuit in the correct orientation.

Wires: Usually it include at least 4 wires - a black and red wire for the solar panel, a brown wire as a jumper and another wire for use in unsoldered testing.

Solar Panel: On your solar panel in the centre of the left side and the right side you will see a small panel of smooth metal - this is the negative/positive terminals. I have marked the positive side by adding black dots on that side. This solar panel will output a max of 3V at 150ma.

Soldering: It is quite possible to use this kit without having to do any soldering at all.

Domestic lighting

Home lighting System is powered by solar energy using solar cells that convert solar energy (sunlight) directly to electricity. The electricity is stored in batteries and used for the purpose of lighting whenever required.

A solar home lighting system (SHLS) is a great way to harness the sun's energy to light up your home and run small home appliances. Home lighting system is a compact, portable and easily mountable, economical solution to all your small energy needs. The solar energy generated by a home lighting system can be stored in the solar battery and used for lighting whenever required.

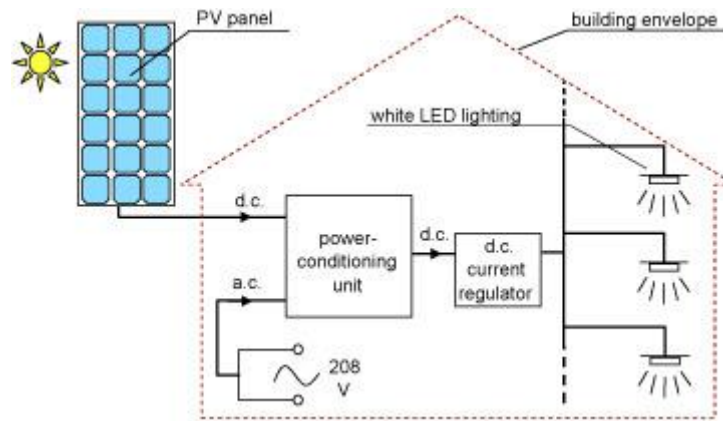

For a small house the Solar Home Lighting System kit includes:

Solar Panels: These 5 watt panels are solid-state semiconductor device that converts the sun's energy directly into electricity.

LED Lamps: Solar Home Lighting system comes equipped with 2 LED Lamps with 18 LEDs per lamp. Each lamp consumes 1.5 W nominal power and is more luminous than a CFL or tube light. These LED lamps have much longer life of approximately 10,000 hrs.

Grid/External Charger: In absence of sunlight, one can charge the system through this external charger that can be directly connected to the main electricity supply.

Control Unit: A compact system with one 7.2/12v S.M.F in-built battery and a controller to protect the battery from overcharging or deep discharge.

The solar module is installed in the open on roof/terrace - exposed to sunlight and the charge controller and battery are kept inside a protected place in the house. The solar module requires periodic dusting for effective performance.

Benefits and features of solar home lighting system

With the advantages that fit in your budget as well as suits your environment, the best Solar Home Lighting System is not only an economical solution but an efficient and a reliable one also. Supplying illumination that is powered from the renewable energy of the sun, the solar cells incorporated in the system transforms the energy of the sun to the electricity. This electricity is preserved in the battery and is used to light up the space whenever required. The

best home lighting is quite compact, easily mountable and portable. These systems are manufactured for the domestic applications. The components of this system include the solar cells, solar battery, charge controller, lamps and the fans.

Street lighting using solar panels

The demand of energy has increased in the world now. So, to fulfill the demands of energy more and more fossil fuels are used, as a result fossil fuels will extinguish in future if they are used at such a rate. To replace the loss of fossil fuels we can use renewable energy as they are freely available and adequate. Solar street lights work on the principle of photovoltaic cell or solar cell.

Solar energy is the radiant energy emitted by sun. Solar energy can be converted into electricity in two ways:

1. Using photovoltaic, or
2. Indirectly using concentrated solar power.

Components of Solar Street Light

Solar panel: This is the prerequisite part of solar street lights, as solar panel will convert solar energy into electrical energy. Solar panels are of two types: Mono-crystalline and Polycrystalline.

Lighting Fixture: LED is used as lighting source of modern solar street light as it provides much higher Lumens with lower energy consumption which is around 50% lower than HPS fixture.

Rechargeable Battery: A rechargeable battery stores the electricity from solar panel during the day time and provides energy to the fixture during the night.

Pole : Street poles are mandatory part to all street lights. This is because there are often components mounted on the top of the pole.

Solar Power System: This system is classified in two broad categories

1. On grid power system is power system energized by photovoltaic panels connected to the utility grid.

2. The term off grid system means self-sufficient living without depending on one or more public utilization.

Solar Street Light Controller: Though solar lighting system is cost efficient and ecofriendly, some people are still hesitant to shift from regular lighting system to solar lighting system because initial investment is required. Let's now understand how solar control system works which will help you understand the merits of using the solar lighting systems.

Solar street lighting system is cost efficient, practical and eco-friendly and very safe way to save energy. It very efficiently tackles with two main problems of today: saving of energy and disposal of incandescent lamps. Energy consumed by the highways now-a-days can also be saved that is the electrical energy by replacing it with solar energy.

Advantages are

1. No requirement of electricity
2. Installation is very easy
3. Operation is very simple and cost of maintenance is low
4. Eco friendly system

Solar Water Pumping

The solar water pumping system uses solar energy to pump water from underground to surface or from lower to higher points on the surface as per requirement. The system consists of a Solar PV module and one motor pump set which is compatible for the PV solar array. Motor pumps may be surface mounted centrifugal or submersible pump sets. Pipe fittings are used to transfer the water to the destination end. The system operates on power generated using solar PV system. The solar panel array converts the solar energy into electrical energy which is used to running the motor pump set. The pumping system draws water from the open well, bore well,

stream, pond, canal etc. The system requires a shadow-free area for installation of the solar panel.

Solar Panels : Photovoltaic pumps are made up of a number of components. There is a photovoltaic array or solar panels which converts solar energy directly into electricity as DC. The pump will have an electric motor to drive it.

Motor: This can be DC or AC. If an AC motor is used then an inverter is also needed. AC motors are more widely available.

Inverters: Inverters have become cheap and efficient and solar pumping systems use special electronically controlled variable-frequency inverters which will optimize matching between the panel and the pump.

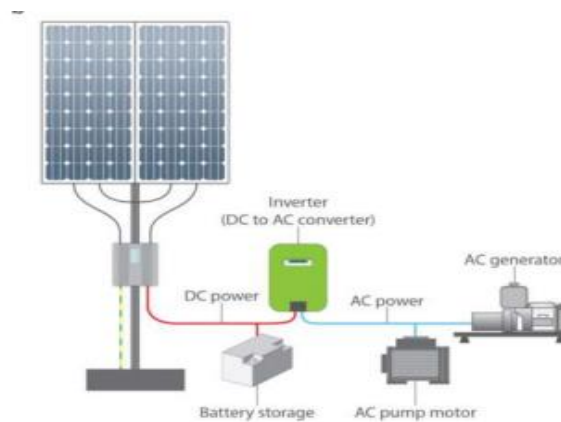

Advantages:

1. No fuel cost because it uses sun light
2. No electricity required for running the motor
3. Long operating life
4. Highly reliable and durable
5. Easy to operate and maintain
6. Eco friendly system